

इंटरनेट

मानक

Disclosure to Promote the Right To Information

Whereas the Parliament of India has set out to provide a practical regime of right to information for citizens to secure access to information under the control of public authorities, in order to promote transparency and accountability in the working of every public authority, and whereas the attached publication of the Bureau of Indian Standards is of particular interest to the public, particularly disadvantaged communities and those engaged in the pursuit of education and knowledge, the attached public safety standard is made available to promote the timely dissemination of this information in an accurate manner to the public.

“जानने का अधिकार, जीने का अधिकार”

Mazdoor Kisan Shakti Sangathan

“The Right to Information, The Right to Live”

“पुराने को छोड़ नये के तरफ”

Jawaharlal Nehru

“Step Out From the Old to the New”

IS 15797 (2008): Roof top rainwater harvesting - Guidelines
[WRD 3: Ground Water and Related Investigations]



“ज्ञान से एक नये भारत का निर्माण”

Satyanarayan Gangaram Pitroda

“Invent a New India Using Knowledge”



“ज्ञान एक ऐसा खजाना है जो कभी चुराया नहीं जा सकता है”

Bhartrhari—Nitiśatakam

“Knowledge is such a treasure which cannot be stolen”

BLANK PAGE



भारतीय मानक
छतों पर वर्षा जल संग्रहण — मार्गदर्शी सिद्धान्त

Indian Standard
ROOF TOP RAINWATER
HARVESTING — GUIDELINES

ICS 13.060.10

© BIS 2008

BUREAU OF INDIAN STANDARDS
MANAK BHAVAN, 9 BAHADUR SHAH ZAFAR MARG
NEW DELHI 110002

FOREWORD

This Indian Standard was adopted by the Bureau of Indian Standards, after the draft finalized by the Ground Water and Related Investigations Sectional Committee had been approved by the Water Resources Division Council.

Rainwater harvesting is an option which has been adopted in many parts of the world where due to increase in population conventional water supply system has failed to meet the needs of the people. The term 'Water Harvesting' connotes collection and storage of rainwater and also other activities aimed at harvesting surface water, prevention of loss through evaporation and seepage.

Natural recharge to ground water has reduced due to shrinkage of open area consequent to increased urban activities. Ground water levels have registered a marked decline, unplanned disposal of waste has resulted in deterioration of ground water quality. In view of the gap between demand and supply there is an utmost need for adopting roof top rainwater harvesting and augmenting ground water storage.

The composition of the Committee responsible for the formulation of this standard is given in Annex A.

For the purpose of deciding whether a particular requirement of this standard is complied with, the final value, observed or calculated, expressing the result of a test or analysis, shall be rounded off in accordance with IS 2 : 1960 'Rules for rounding off numerical values (*revised*)'. The number of significant places retained in the rounded off value should be the same as that of the specified value in this standard.

Indian Standard

ROOF TOP RAINWATER HARVESTING — GUIDELINES

1 SCOPE

This standard lays down guidelines for roof top rain-water harvesting.

2 REFERENCE

The following standard contains provision, which through reference in this text constitutes provision of this standard. At the time of publication, the edition indicated was valid. All standards are subject to revision and parties to agreements based on this standard are encouraged to investigate the possibility of applying the most recent edition of the standard given below:

<i>IS No.</i>	<i>Title</i>
14476 (Part 6) : 1998	Test pumping of water wells — Code of practice: Part 6 Special tests

3 GENERAL

Roof top rainwater collection is one of the solutions for solving or reducing the problem of water availability, where there is inadequate ground water supply and surface sources are either lacking or insignificant. In this system, rainwater falling on roofs of houses and other buildings is collected through a system of pipes and semi-circular channels of galvanized iron or PVC and stored in tanks suitably located on the ground or underground for direct use or for recharging ground water aquifers. Urban housing complexes/residential buildings and institutional buildings have large roof area and are amendable for rainwater harvesting. This practice is in vogue at the individual household level in remote hilly areas with high rainfall and in some semi-arid areas in the plains.

4 ADVANTAGES OF ROOF TOP RAINWATER HARVESTING

- a) One of the appropriate options for augmenting ground water recharge/storage in urban areas, where natural recharge has been considerably reduced due to increased urban activities and not much land is available for implementing any other artificial recharge measure. In rural areas also, roof top rainwater harvesting can supplement the domestic requirements.
- b) Rainwater runoff, which otherwise flows through sewers and storm drains and is wasted, can be harvested and utilized.
- c) Helps in reducing the frequent drainage congestion in urban areas where fast rate of urbanization has reduced availability of open surfaces.
- d) Recharging of aquifers with harvested water improves the quality of ground water through dilution.
- e) The harnessed rainwater can be utilized when needed at the time and place of scarcity.
- f) The structures required for harvesting are simple, economical and Eco-friendly.
- g) In coastal areas over extraction of ground water leads to saline water ingress. Therefore, recharging of ground water aquifer in such areas helps to control saline water ingress.
- h) Storing of harvested water under ground through aquifer recharge, wherever feasible, is advantageous as such storage is not exposed to evaporation and pollution. Aquifers serve as a distribution system as well supplying water when required.

5 FACTORS DETERMINING TYPE/SYSTEM OF RAINWATER HARVESTING

5.0 There are many factors that determine the total quantity of rainwater that can be harvested in a particular area and the system that would be appropriate for efficiently harvesting this quantity. Some of these are given in 5.1 to 5.5.

5.1 Rainfall Quantity

The total volume of rainwater available from any roof top surface is a product of total rainfall and the surface area of collection. A runoff coefficient is usually applied to account for infiltration, evaporation and other losses and it varies from 0.8 to 0.95. In order to estimate the average annual/monsoon runoff from rooftop area in any location, the average annual/monsoon rainfall data for the location need to be used and using Tables 1 and 2, the water availability for flat and sloping roof can be worked out.

5.2 Rainfall Pattern

Rainfall pattern as well as total rainfall, will often determine the feasibility of a rainwater harvesting system. In areas where rainfall occurs regularly in most parts throughout the year, implies that the storage requirement is low and hence the system cost will be

Table 1 Water Availability for a Given Roof Top Area and Rainfall (For Flat Roofs)
(Clause 5.1)

Sl No.	Roof Top Area m ²	Rainfall, mm												
		100	200	300	400	500	600	800	1 000	1 200	1 400	1 600	1 800	2 000
(1)	(2)	(3)	(4)	(5)	(6)	(7)	(8)	(9)	(10)	(11)	(12)	(13)	(14)	(15)
i)	20	1.6	3.2	4.8	6.4	8	9.6	12.8	16	19.2	22.4	25.6	28.8	32
ii)	30	2.4	4.8	7.2	9.6	12	14.4	19.2	24	28.8	33.6	38.4	43.2	48
iii)	40	3.2	6.4	9.6	12.8	16	19.2	25.6	32	38.4	44.8	51.2	57.6	64
iv)	50	4	8	12	16	20	24	32	40	48	56	64	72	80
v)	60	4.8	9.6	14.4	19.2	24	28.8	38.4	48	57.6	67.2	76.8	86.4	96
vi)	70	5.6	11.2	16.8	22.4	28	33.6	44.8	56	67.2	78.4	89.6	100.8	112
vii)	80	6.4	12.8	19.2	25.6	32	38.4	51.2	64	76.8	89.6	102.4	115.2	128
viii)	90	7.2	14.4	21.6	28.8	36	43.2	57.6	72	86.4	100.8	115.2	129.6	144
ix)	100	8	16	24	32	40	48	64	80	96	112	128	144	160
x)	150	12	24	36	48	60	72	96	120	144	168	192	216	240
xi)	200	16	32	48	64	80	96	128	160	192	224	256	288	320
xii)	250	20	40	60	80	100	120	160	200	240	280	320	360	400
xiii)	300	24	48	72	96	120	144	192	240	288	336	384	432	480
xiv)	400	32	64	96	128	160	192	256	320	384	448	512	576	640
xv)	500	40	80	120	160	200	240	320	400	480	560	640	720	800
xvi)	1 000	80	160	240	320	400	480	640	800	960	1 120	1 280	1 440	1 600
xvii)	2 000	160	320	480	640	800	960	1 280	1 600	1 920	2 240	2 560	2 880	3 200
xviii)	3 000	240	480	720	960	1 200	1 440	1 920	2 400	2 880	3 360	3 840	4 320	4 800

Table 2 Water Availability for a Given Roof Top Area and Rainfall (For Sloping Roofs)
(Clause 5.1)

Sl No.	Roof Top Area m ²	Rainfall, mm												
		100	200	300	400	500	600	800	1 000	1 200	1 400	1 600	1 800	2 000
(1)	(2)	(3)	(4)	(5)	(6)	(7)	(8)	(9)	(10)	(11)	(12)	(13)	(14)	(15)
i)	20	1.9	3.8	5.7	7.6	9.5	11.4	15.2	19	22.8	26.6	30.4	34.2	38
ii)	30	2.9	5.7	8.6	11.4	14.3	17.1	22.8	28.5	34.2	39.9	45.6	51.3	57
iii)	40	3.8	7.6	11.4	15.2	19	22.8	30.4	38	45.6	53.2	60.8	68.4	76
iv)	50	4.8	9.5	14.3	19	23.8	28.5	38	47.5	57	66.5	76	85.5	95
v)	60	5.7	11.4	17.1	22.8	28.5	34.2	45.6	57	68.4	79.8	91.2	102.6	114
vi)	70	6.7	13.3	20.0	26.6	33.3	39.9	53.2	66.5	79.8	93.1	106.4	119.7	133
vii)	80	7.6	15.2	22.8	30.4	38	45.6	60.8	76	91.2	106.4	121.6	136.8	152
viii)	90	8.6	17.1	25.7	34.2	42.8	51.3	68.4	85.5	102.6	119.7	136.8	153.9	171
ix)	100	9.5	19	28.5	38	47.5	57	76	95	114	133	152	171	190
x)	150	14.3	28.5	42.8	57	71.3	85.5	114	142.5	171	199.5	228	256.5	285
xi)	200	19	38	57	76	95	114	152	190	228	266	304	342	380
xii)	250	23.8	47.5	71.3	95	118.8	142.5	190	237.5	285	332.5	380	427.5	475
xiii)	300	28.5	57	85.5	114	142.5	171	228	285	342	399	456	513	570
xiv)	400	38	76	114	152	190	228	304	380	456	532	608	684	760
xv)	500	47.5	95	143	190	237.5	285	380	475	570	665	760	855	950
xvi)	1 000	95	190	285	380	475	570	760	950	1 140	1 330	1 520	1 710	1 900
xvii)	2 000	190	380	570	760	950	1 140	1 520	1 900	2 280	2 660	3 040	3 420	3 800
xviii)	3 000	285	570	855	1 140	1 425	1 710	2 280	2 850	3 420	3 990	4 560	5 130	5 700

correspondingly low and *vice versa*. Conversely, areas where total rainfall occurs during 1-2 months, the water collected during the monsoon has to be stored for use in remaining months throughout the year, which requires large storage structures as well as arrangement for some treatment.

5.3 Intensity of Rainfall

The maximum intensity of rainfall will decide the peak flow, which is to be harvested and depending upon the peak flow, the gutter size for sloping roof and diameter of drainage pipe has to be calculated.

5.4 Collection Surface Area

For roof top rainwater harvesting, the collection area is restricted by the size of the roof of the dwelling unit. Sometimes other surfaces such as terrace, balconies and other projections are used to supplement the roof top collection area.

5.5 Storage Capacity

The storage tank is usually the most expensive component of rainwater harvesting system. Hence a careful analysis is required for design of storage tank capacity.

6 STORAGE OF WATER IN A STORAGE TANK FOR DIRECT USE

6.1 Design of System Components

A roof top catchment system has three main components, namely, a roof, a guttering and first flush device and a storage tank:

- a) *Roof* — In this system, only roof top is the catchment as shown in Fig. 1 and Fig. 2. The roofing should be of galvanized iron sheets (G.I.), aluminium, clay tiles, asbestos or

concrete. In case of thatch-roof, it may be covered with waterproof LDPE sheeting. The roof should be smooth, made of non-toxic material sufficiently large to fill the tank with the available rainfall conditions. Existing roofs of houses and public buildings can be used for a roof top catchment system. In some cases enlarged or additional roofed structures can be built.

- b) *Guttering and First-Flush Device* — Guttering is intended to protect the building by collecting the water running of the roof and direct it, via a downpipe, to the storage tank. Gutter is provided along the edge of the roof. It is fixed with a gentle slope towards downpipe, which is meant for free flow of water to the storage tank. This may be made up of G.I. sheet, wood, bamboo or any other locally available material. The downpipe used should be at least 100 mm diameter and be provided with a 20 mesh wire screen at the inlet to prevent dry leaves and other debris from entering it. The gutter size may be worked out using any standard formula of hydraulics or using Table 3.

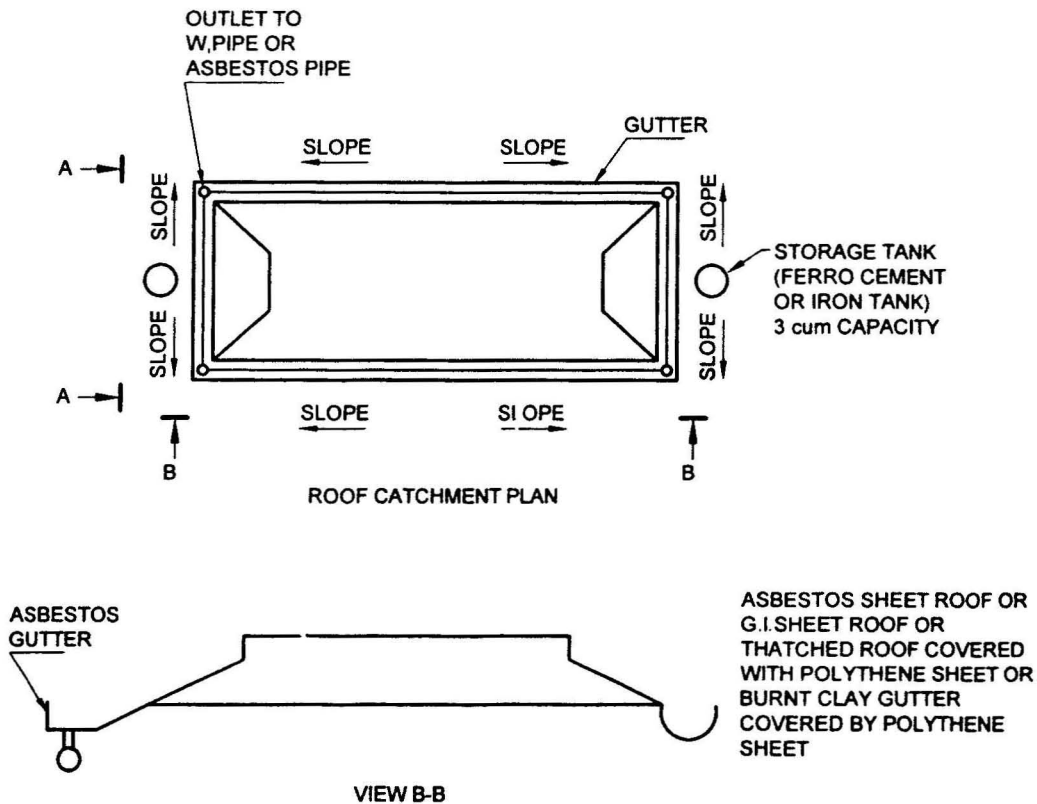
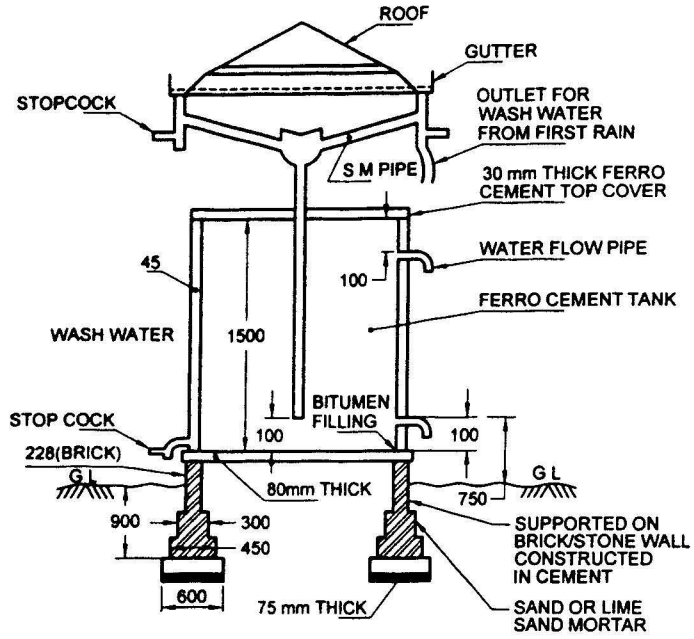
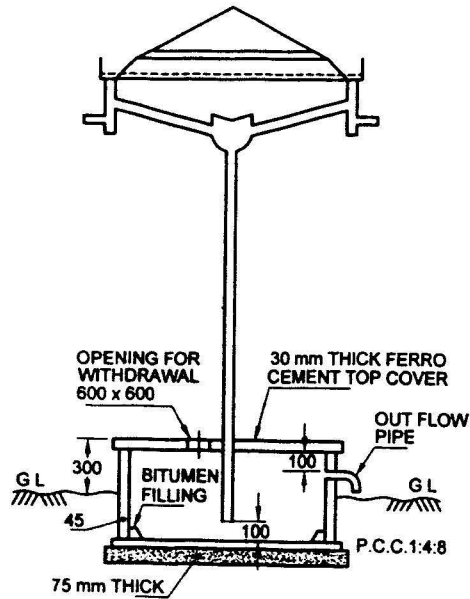

FIG. 1 RAINWATER HARVESTING SYSTEM



WATER TANK ABOVE GROUND



WATER TANK UNDER GROUND

All dimensions in millimetres.

FIG. 2 RAINWATER HARVESTING STRUCTURES

Table 3 Diameter of Gutter and Width of G.I. Sheet
[Clause 6.1(b)]

Sl No.	Roof Top Area m ²	Rainfall Intensity, mm h															
		10	15	20	25	30	35	40	45	50	60	70	80	90	100		
		Diameter (D) of Channel and Width (W) of G.I. Sheet (mm)															
(1)	(2)	(3)	(4)	(5)	(6)	(7)	(8)	(9)	(10)	(11)	(12)	(13)	(14)	(15)	(16)	(17)	
i)	10	D	20	23	26	28	30	32	33	35	36	39	41	43	45	47	
		W	51	56	60	64	67	70	72	74	77	81	84	88	91	93	
ii)	20	D	26	30	33	36	39	41	43	45	47	50	53	56	58	61	
		W	60	67	72	77	81	84	88	91	93	99	103	108	112	115	
iii)	30	D	30	35	39	42	45	48	50	52	54	58	62	65	68	71	
		W	67	74	81	86	91	95	99	102	106	112	117	122	127	131	
iv)	40	D	33	39	43	47	50	53	56	58	61	65	69	72	76	79	
		W	72	81	88	93	99	103	108	112	115	122	128	134	139	144	
v)	50	D	36	42	47	51	54	58	61	63	66	71	75	79	82	86	
		W	77	86	93	100	106	111	115	120	124	131	138	144	149	154	
vi)	60	D	39	45	50	54	58	62	65	68	71	76	80	84	88	92	
		W	81	91	99	106	112	117	122	127	131	139	146	152	158	164	
vii)	70	D	41	48	53	58	62	65	69	72	75	80	85	89	93	97	
		W	84	95	103	111	117	123	128	133	138	146	153	160	167	172	
viii)	80	D	43	50	56	61	65	69	72	76	79	84	89	94	98	102	
		W	88	99	108	115	122	128	134	139	144	152	160	167	174	180	
ix)	90	D	45	52	58	63	68	72	76	79	82	88	93	98	102	107	
		W	91	102	112	120	127	133	139	144	149	158	167	174	181	188	
x)	100	D	47	54	61	66	71	75	79	82	86	92	97	102	107	111	
		W	93	106	115	124	131	138	144	149	154	164	172	180	188	194	
xi)	150	D	54	63	71	77	82	87	92	96	100	107	113	119	124	129	
		W	106	120	131	141	149	157	164	170	176	188	197	207	215	223	
xii)	200	D	61	71	79	86	92	97	102	107	111	119	126	132	138	144	
		W	115	131	144	154	164	172	180	188	194	207	218	228	237	246	
xiii)	250	D	66	77	86	93	100	105	111	116	121	129	137	144	150	156	
		W	124	141	154	166	176	186	194	202	209	223	235	246	256	266	
xiv)	300	D	71	82	92	100	107	113	119	124	129	138	146	154	161	167	
		W	131	149	164	176	188	197	207	215	223	237	250	262	273	283	
xv)	400	D	79	92	102	111	119	126	132	138	144	154	163	172	179	186	
		W	144	164	180	194	207	218	228	237	246	262	276	290	302	313	
xvi)	500	D	86	100	111	121	129	137	144	150	156	167	177	186	195	203	
		W	154	176	194	209	223	235	246	256	266	283	299	313	326	339	
xvii)	1 000	D	111	129	144	156	167	177	186	195	203	217	230	242	253	263	
		W	194	223	246	266	283	299	313	326	339	361	381	400	417	433	
xvii)	2 000	D	144	167	186	203	217	230	242	253	263	282	298	314	328	341	
		W	246	283	313	339	361	381	400	417	433	462	489	513	535	556	
xviii)	3 000	D	167	195	217	236	253	268	282	294	306	328	347	365	382	397	
		W	283	326	361	391	417	441	462	482	501	535	566	594	620	644	

NOTES

- 1 Provide minimum diameter of channel of 100 mm and width of sheet 176 mm.
- 2 Diameter to be limited to 300 mm and width of sheet 510 mm.

For all tanks having roof catchment, the first runoff of rainwater from the roof should be discarded. This helps keep the water potable because this first flush contains large quantities of dust, leaves and other impurities. This can also be prevented by installation of a gate valve at the end of down pipe at ground level.

- c) *Tank* — Storage tank can be constructed underground or above ground. The

underground tank may be of masonry or R.C.C. structure suitably lined with water proofing materials. The surface tank may be of G.I. Sheet, R.C.C., Plastic/HDP or Ferrocement Tank placed at elevation on a raised platform as shown in Fig. 3. Choice of the tank depends on locally available materials and space available. When the tank is constructed underground, at least 30 cm of the tank should remain above ground. Water

tanks using ferrocement technology come in different designs with volumes ranging between 2 m³ and 200 m³. For example, a free standing cylindrical tank can be built in sizes between 10 m³ and 30 m³, while a capacity of up to 200 m³ is possible with sub-surface covered tanks. The latter is economical when the capacity exceeds 50 m³.

An alternate design, avoiding framework, involves erecting a circular frame made of welded-mesh bars spaced at 15 cm and covered with chicken wire mesh (2.5 cm gauge) onto a reinforced concrete base. This is then covered on the outside with sacks or cloth and two coats of a 1.5 cm layer of mortar (1 part cement, 3 parts sand) and plastered along the inner walls to produce the tank wall. Two further coats of plaster are added, one on the outside after removing the sacks and one on the inside to provide a tank wall thickness of 5 cm. A waterproof coat of cement and water is then added to the tank's inner wall.

When the wall is complete, a wooden frame is constructed inside the tank to support the metal template made from old oil drums, which forms the mould for the domed roof. The roof is also reinforced with welded-mesh and chicken wire. For quality, the floor, walls and the roof need to be cured by moistening their surface for at least a week. This should start immediately after each component is ready.

To facilitate cleaning of the tank, an outlet pipe may be fitted and fixed in the tank at bottom level. The size of the tank will depend upon the factors such as daily demand, duration of dry spell, catchment area and rainfall.

The tank is provided with:

- a) A manhole of 0.60 m × 0.60 m size with cover,
- b) Vent pipe/overflow pipe of 100 mm diameter, and
- c) Drain pipe of 100 mm diameter at bottom.

The withdrawal of water from the underground tank is

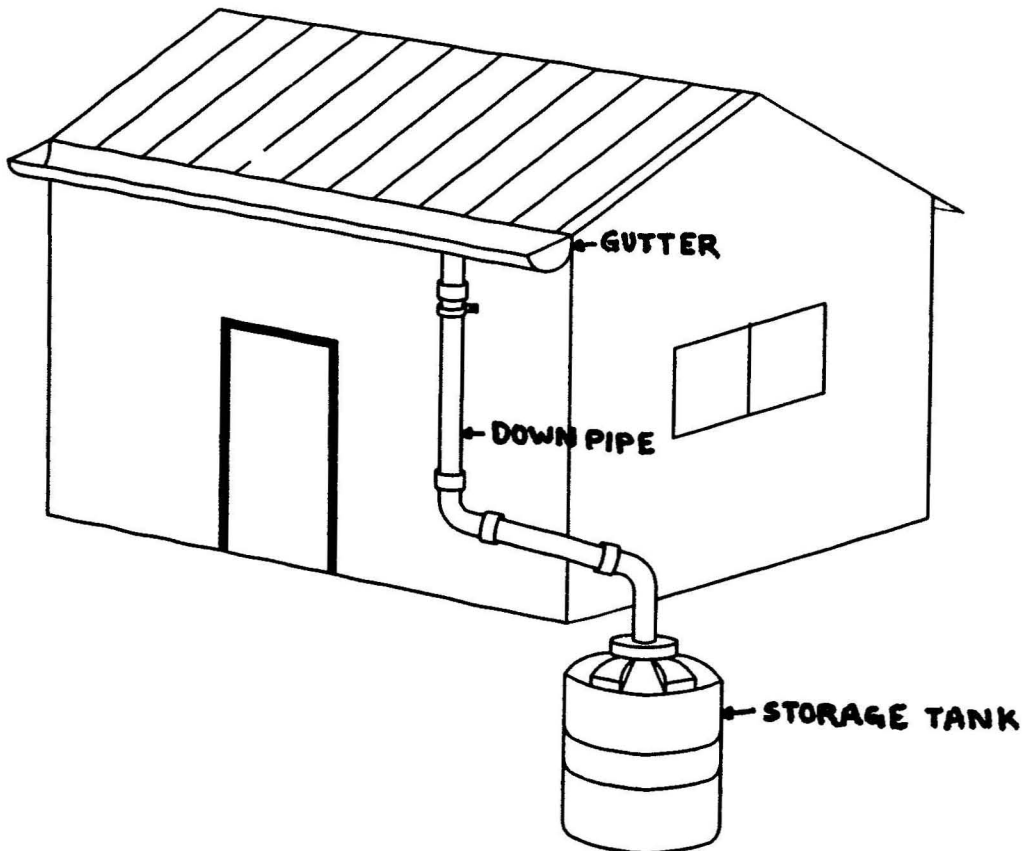

FIG. 3 STORAGE OF RAINWATER IN A HDPE TANK

done by installing a hand pump . In case of surface tank, taps may be provided. The overflow pipe should be connected to a drain/recharge pit.

Before the tank is put into use it should be thoroughly cleaned and disinfected with high dosage of chlorine. Since the water should remain stored for quite a long time, periodical disinfection of stored water is essential to prevent growth of pathogenic bacteria.

6.2 Site Assessment

Assessing the site conditions is the first step towards a sound system design. The five main site conditions to be assessed are:

- a) Availability of suitable roof catchment,
- b) Foundation characteristics of soil near the house,
- c) Location of trees,
- d) Estimated runoff to be captured per unit area of the roof, and
- e) Availability and location of construction material.

6.3 Estimating the Size of the Required System

The size of the catchment area and tank should be enough to supply sufficient water for the users during the dry period. Assuming a full tank at the beginning of the dry season (and knowing the average length of the dry season and the average water use), the volume of the tank can be calculated by the following formula:

$$V = t \times n \times q$$

where

- V = volume of tank, in litres;
 t = length of the dry season (days);
 n = number of people using the tank; and
 q = consumption in litres per capita per day.

If, for example, 20 lpd (q) is agreed upon and a dry period of 100 days (t) is normally not exceeded, a storage volume of 10 m³ would be required for a family of 5 members (n).

$$V = 100 (t) \times 5 (n) \times 20 (q) = 10\,000 \text{ litre or } 10 \text{ m}^3$$

The required catchment area (that is the area of the roof) can be determined by dividing the volume of the tank by the accumulated average rainfall volume (in litres) per unit area (in m²) over the preceding wet months and multiplying this with the runoff coefficient, which varies from 0.8 to 0.95 depending upon type of roof.

6.4 General Design Features

Roof top water harvesting systems can provide good

quality potable water, if the design features outlined below are taken into account:

- a) The substances that go into the making of the roof should be non-toxic and chemically inert.
- b) Roof surfaces should be smooth, hard and dense since they are easier to clean and are less likely to be damaged and release materials/fibres into the water.
- c) Roof painting is not advisable since most paints contain toxic substances and may peel off.
- d) No overhanging trees should be left near the roof.
- e) Nesting of birds on the roof should be prevented.
- f) All gutter ends should be fitted with a wire mesh screen to keep out leaves, etc.
- g) Appropriate arrangement for discarding the first flow of rainfall should be made.
- h) A hygienic soak away channel should be built at water outlets and a screened overflow pipe should be provided.
- j) The storage tank should have a tight fitting roof that excludes light, a manhole cover and a flushing pipe at the base of the tank (for standing tanks).
- k) There should be a reliable sanitary extraction device such as a gravity tap or a hand pump to avoid contamination of the water in the tank.
- m) There should be no possibility of contaminated wastewater flowing into the tank (especially for tanks installed at ground level).
- n) Water from other sources, unless it is a reliable source, should not be emptied into the tank through pipe connections or the manhole cover.

6.5 Management and Maintenance

Roof top catchment tanks, like all water supply systems, demand periodic management and maintenance to ensure reliable and quality water supply. If the various components of the system are not regularly cleaned, water use is not properly managed, problems are not identified or necessary repairs not performed, the roof catchment system will cease to provide reliable and good quality water.

Following is a time table of maintenance and management requirements that can provide a basis for monitoring and checking:

- a) During the rainy season, the whole system (roof catchment, gutters, pipes, screens, first-

flush and overflow) should be checked before and after each rain and preferably cleaned after every dry period exceeding a month.

- b) At the end of the dry season and just before the first shower of rain is anticipated, the storage tank should be scrubbed and flushed of all sediment and debris (the tank should be refilled afterwards with a few centimeters of clean water to prevent cracking). Ensure timely service (before the first rains are due) of all tank fixtures, including replacement of all worn screens and servicing of the outlet tap or hand pump.

6.6 Water Use Management

Control over the quantity of water abstracted from the tank is important to optimize water use. Water use should be managed so that the supply is sufficient to last through the dry season. Failure to do so will mean exhausting all the stored water. On the other hand, underutilization of the water source due to severe rationing should also be avoided.

7 RECHARGE OF HARVESTED RAINWATER IN AQUIFERS

7.0 The runoff water collected from roof tops can artificially recharge and augment the depleting ground water resources especially in the urban areas, where the natural recharge has diminished considerably. The areas having depth to water table greater than 8 m below ground level and underlain by permeable strata are suitable for artificial recharge.

7.1 Design of Efficient Artificial Recharge Structures

The design involves consideration of data on hydrological and hydrogeological aspects and hydrometeorological parameters. The background information to be collected is as given below:

- a) Layout plan of the area.
- b) Demarcation of the roof, paved and open areas.
- c) Delineation of storm water drains and flow of storm water.
- d) Details of the existing ground water abstraction structures in and around the vicinity of the project site.
- e) Computation of the runoff for recharge.

Apart from the above mentioned parameters, selection of appropriate recharge structure depends on the availability of space for construction of recharge structures and invert levels of storm water drains at inlets to recharge structures. While preparing the

recharge scheme, depth and shape of the storage facility in recharge structure depends on the availability of runoff, depth of storm water drainage and space availability in an area. The recharge scheme as prepared may also be got vetted by appropriate authorities and experts to incorporate suggestions for improvement.

7.2 Recharge Structures

The most suitable recharge structures for roof top rain water harvesting are:

- a) Recharge pits;
- b) Recharge trenches;
- c) Recharge through dry or operational dugwells;
- d) Recharge through abandoned/existing tube wells; and
- e) Recharge wells, etc.

7.2.1 Recharge Pits

- a) In alluvial areas where permeable rocks are exposed on the land surface or at very shallow depth, recharge pits are suitable for artificial recharge of water collected from the roof tops.
- b) The technique is suitable for buildings having a roof area of 100 m². The recharge pits are constructed for recharging the shallow aquifers.
- c) Recharge pits may be of any shape and size and are generally constructed 1 to 2 m wide and 2 to 3 m deep which are backfilled with boulders (5-20 cm), gravels (5-10 mm), and coarse sand (1.5-2 mm) in graded form — boulders at the bottom, gravels in between and coarse sand at the top so that the silt content that will come with runoff will be deposited on the top of the coarse sand layer and can easily be removed. For smaller roof area, pit may be filled with broken bricks/cobbles.
- d) A mesh should be provided at the roof so that leaves or any other solid waste/debris are prevented from entering the pit and a desilting/ collection chamber may also be provided at the ground to arrest the flow of finer particles to the recharge pit.
- e) The top layer of sand should be cleaned periodically to maintain the recharge rate.

7.2.2 Recharge Trenches

- a) Recharge trenches are suitable for buildings having roof area of 200-300 m² and where permeable strata is available at shallow depths.
- b) Trench may be 0.5 to 1 m wide, 1 to 1.5 m

deep and 10 to 20 m long depending upon availability of water to be recharged.

- c) These are backfilled with boulders (5-20 cm), gravels (5-10 mm), and coarse sand (1.5-2 mm) in graded form — boulders at the bottom, gravel in between and coarse sand at the top so that the silt content that will come with runoff will be deposited on the top of the sand layer and can easily be removed.
- d) A mesh should be provided at the roof so that leaves or any other solid waste/debris is prevented from entering the trench and a desilting/collection chamber may also be provided on ground to arrest the flow of finer particles to the trench.
- e) The top layer of sand should be cleaned periodically to maintain the recharge rate.

7.2.3 Recharge Through Dry or Operational Dug Wells (see Fig. 4)

- a) Dry/operational dug wells if exist in the area may be utilized as recharge structures after cleaning and desilting the same.
- b) Recharge water is guided through a pipe from desilting chamber to the bottom of the well or below the water level to avoid scouring of bottom and entrapment of air bubbles in the aquifer.

- c) Recharge water should be silt-free. For removing the silt content, the runoff water should pass either through a desilting chamber or filter chamber.
- d) Periodic chlorination should be done for controlling the bacteriological contamination in operational dug well.
- e) Wire mesh filter should be provided just before the inlet to avoid entry of any foreign material, tree leaves, etc, in to the dug well.

7.2.4 Recharge Through Abandoned/Existing Tube Wells (see Fig. 5 and Fig. 6)

- a) Abandoned/existing tube wells may be used as recharge structures.
- b) The abandoned tube well should be properly developed before use as recharge structure.
- c) PVC pipes of 10 cm diameter are connected to roof drains to collect rainwater.
- d) The first roof runoff is drained through the bottom of drain pipe if existing tube well is used as recharge structure. After closing the bottom pipe, the rainwater of subsequent rain showers is taken through a 'Tee' to an online PVC filter in case of small roofs. If the roof area is larger, a filter pit may be provided. Rainwater from roofs is taken to collection/

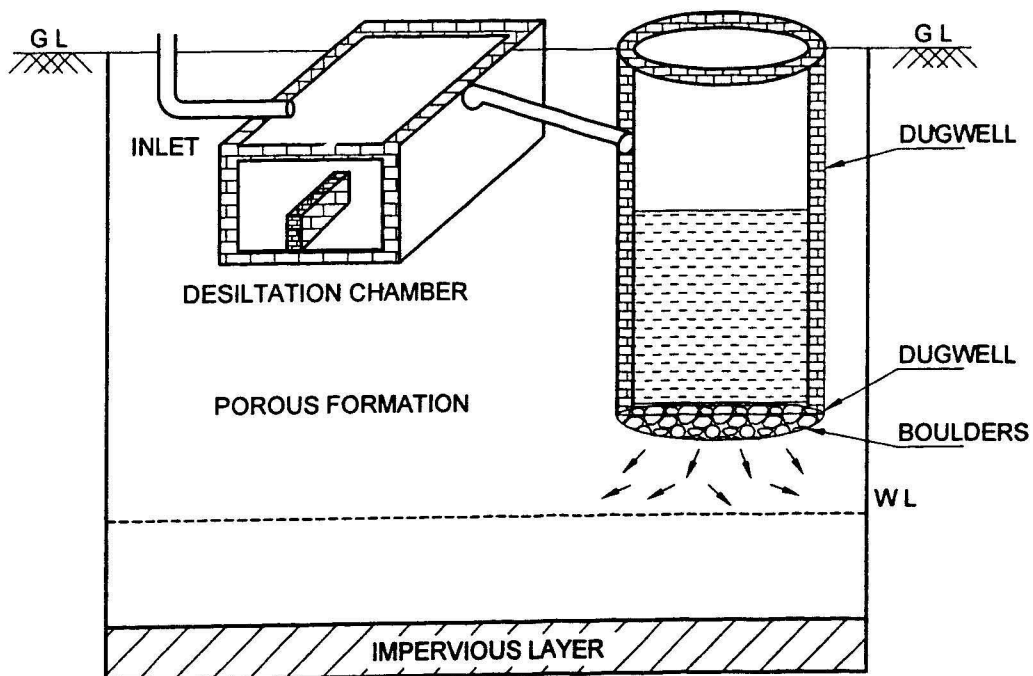

FIG. 4 RECHARGE THROUGH DUG WELL

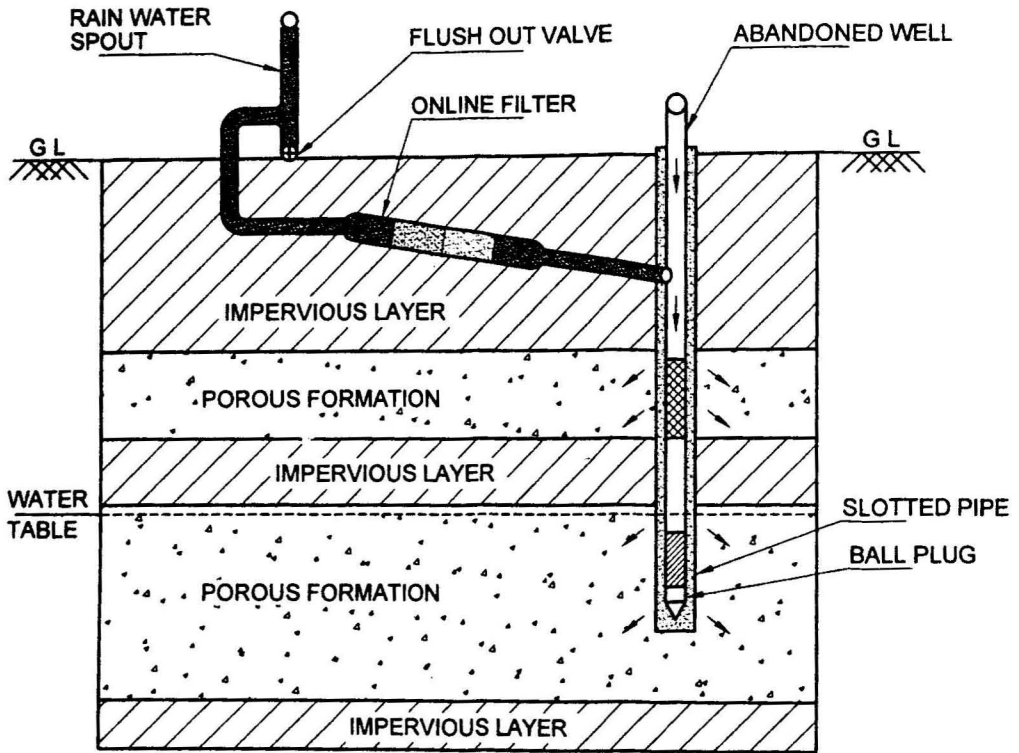
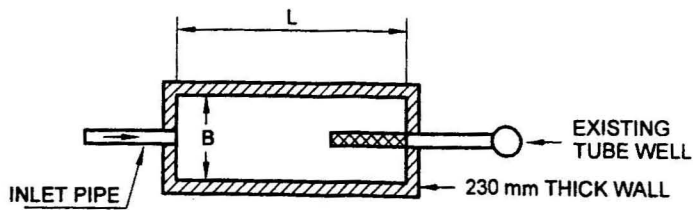
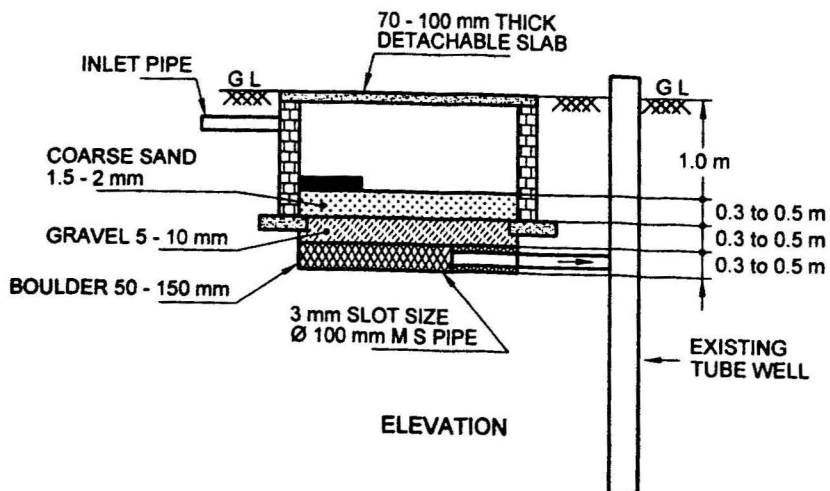

FIG. 5 RECHARGE THROUGH ABANDONED TUBE WELL



PLAN



ELEVATION

FIG. 6 RECHARGE THROUGH EXISTING TUBE WELL

desilting chambers located on ground. These collection chambers are interconnected as well as connected to the filter pit through pipes.

- e) A connecting pipe with recharge well is provided at the bottom of the pit for recharging of filtered water through well.
- f) Wire mesh filter should be provided just before the inlet to avoid entry of any foreign material, tree leaves, etc., in to the system.

7.2.5 Recharge Wells (see Fig. 7)

- a) In areas where the aquifers are overlain by a considerable thickness of impervious formation, a new recharge tube well can be constructed for recharging the harvested rainwater.
- b) It is used for recharging single/multiple aquifers.
- c) A settlement-cum-storage tank is constructed near the tube well for settlement of silt particles and storage of excess water.
- d) Roof top water is diverted to the settlement tank through pipes.

- e) Clear water of storage tank is diverted to the recharge tube well for recharge.
- f) It is suitable for recharging roof top rainwater of big buildings/blocks.
- g) If runoff availability is less, then online filter may be used in the pipe line connecting roof water with recharge well.

7.2.5.1 Construction of recharge well

These are drilled by deploying the appropriate rig unit or by hand boring as per the site conditions and depth of the tube wells.

A well assembly of pipes with diameters varying from 100 to 250 mm may be lowered throughout the depth. Both M.S. and PVC pipes can be used. PVC pipes are rigid, light pipes in 6 or 9 m lengths available in all diameters. The main advantage of PVC pipes is their resistance to corrosion and slots of the pipes will not close with time. As the slotted pipes in recharge wells are in fluctuation zones of water levels, slots of M.S. pipes may become closed due to rusting. The main drawback of PVC pipes is that, these pipes can not be used in large diameter recharge wells. M.S. Pipes may be coated with bituminous coating to avoid rusting.

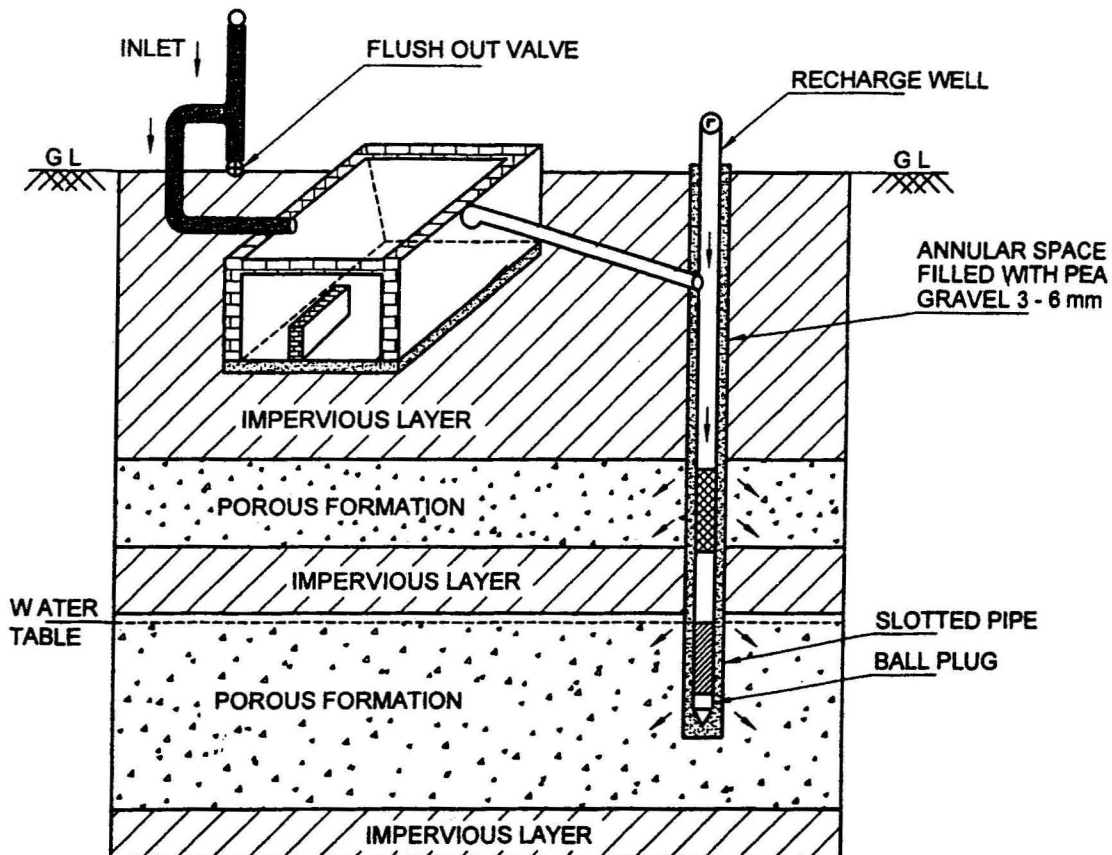

FIG. 7 RECHARGE THROUGH BORE WELL

After excavation of the recharge trench/shaft or filtration chamber is over, pipes should be rechecked and cleaned with wire brush. Depth sounding of recharge wells should be taken with tape to make sure that no silt or soil has gone into the recharge wells during the excavation of trench/shaft. Width of slots in recharge well should be in accordance with the aquifer system encountered. Slotted pipes should be placed against the aquifer or dried-up aquifers encountered in the recharge wells. A slotted pipe at the top of the recharge well will need to be placed to permit the entry of clean/clear water into the recharge well.

The annular space around the well assembly may be shrouded with appropriate size of gravel. The gravel should be washed so that it is silt-free. The recharge tube well should be developed by low capacity air compressor or by bailing method as required. The well may also be cleaned and developed by pouring the water from outside if required. The water levels of the tube well should be recorded and the well covered with cap with a provision to monitor the well in future. A vent pipe of about one inch diameter is also recommended which can act as escape for gases and for measuring the water levels. Once the recharge trench or shaft is constructed around the recharge tube well, recharge wells may be developed with hand bailers to avoid the disturbance of filter media.

7.2.5.2 Recharge ability test

To test the recharge ability of the tube well, a slug test may be conducted [see IS 14476 (Part 6)].

7.3 Filters

Generally, the following two types of filters are used :

- a) *Online Filter*
 - 1) This filter is used when availability of runoff as well as recharge rate of recharge well is less.
 - 2) Manufactured from reinforced engineering plastic material.
 - 3) Available in various sizes and flow rates ranging from 3 to 25 m³/h.
 - 4) Easy to open and clean.
- b) *Purpose Built Filter*
 - 1) The filter material recommended is coarse sand of 1.5 to 2 mm size at the top, followed by gravel of 5 to 10 mm size, and boulders of 5 to 20 cm at bottom. The thickness of each layer should be about 0.5 m. Coarse sand should be placed at the top so that the silt content that comes with runoff will be deposited on the top of the coarse sand/

pea gravel and can easily be removed. For smaller roof area the pit may be filled with overburnt broken bricks/cobbles.

- 2) After excavation of filter chamber, boulders and gravel should be filled up first to the foundation of wall of the structure.
- 3) After filling of boulder and gravel, filter material should be covered with polythene/jute bags to avoid spilling of construction material, which may damage the filter bed. After the construction of walls, the polythene/jute bags should be removed and the sand/pea gravels filled up to the recommended depth as per the design.
- 4) Filter media should be free from silt and any other foreign material. Before putting the filter material into the chamber, filter material should be sieved and washed to remove all the finer material. During operation the scouring effect of flow of water into the structure should be checked upon and if flow is disturbing the filter media, the water can be released near the filter media. This can be done by providing an 'I' shape joint in the inlet pipe in trench.
- 5) Regular inspection of filter material is essential in recharge structures. Silt deposited on the filter media should be cleaned regularly. Once in a year the top 5-10 cm sand/pea gravel layer should also be scraped to maintain a constant recharge rate through filter material.
- 6) Growth of grass or bushes hampers the filtration rate of the chamber. The grass and bushes should be cleared regularly.

7.4 Maintenance of Catchment Area, Water Drains and Recharge Structures

- a) The catchments should be neat and clean. The roof top/terrace of the building spaces around the buildings should not be used for dumping of unwanted items and scrap material.
- b) The washing machine water having heavy dose of detergents should not be allowed to enter into the water drains which are connected with recharge structures.
- c) Open water drains covered with perforated detachable RCC slabs are best as the maintenance of these drains is easy and pollution, especially bacteriological pollution, can be avoided. If the storm water drainage is through pipe system, provide manholes and

- chambers at regular intervals as well as close to the suspected silt and waste accumulation places within the channel.
- d) Protect the drainage system from tree leaves, polythene bags, plastic bottles and pouches of eatables.
 - e) Put up sign boards mentioning that the campus of building is equipped with rainwater harvesting system which is being recharged to the ground water system. Mention the ill effects and health impacts if the storm water drains are not properly maintained. Educate the staff maintaining the storm water drains to keep the drains neat and clean.
 - f) Provide wire mesh filter just before the inlet. Provide silt check wall within the drain bed at a convenient place. If more silt is expected provide check wall at regular intervals in the storm water drains.
 - g) The periodic removal of the material deposited on the surface be done by scraping
- h) Precaution should be taken to avoid domestic waste water entering into the recharge structures.
 - j) Recharge tube wells should be developed periodically by hand bailers to avoid clogging of the slots.
 - k) Before the arrival of monsoon, the roof top as well as drains should be properly cleaned.
 - m) Length and placement of the slotted pipe should be finalized after drilling of pilot hole for tube well.
 - n) Recharge water should be introduced into the structure at its lowest point to prevent erosion and disturbance of filter material.
 - p) A wire mesh should be placed at the entrance of recharge structures.
 - q) Periodic cleaning of collection chambers should be carried out to remove the plastic bags, leaves, etc, which may choke the entry of water recharge structures.

ANNEX A

(Foreword)

COMMITTEE COMPOSITION

Ground Water and Related Investigations Sectional Committee, WRD 3

<i>Organization</i>	<i>Representative(s)</i>
Central Ground Water Board, New Delhi	SHRI B. M. JHA (<i>Chairman</i>) [Member (SAM)]
Central Electricity Authority, Hyderabad	SHRI MAJOR SINGH SHRI S. B. ATRI (<i>Alternate</i>)
Central Ground Water Board, Faridabad	DR S. K. JAIN SHRI S. K. SINHA (<i>Alternate</i>)
Central Pollution Control Board, New Delhi	DR R. C. TRIVEDI DR SANJEEV AGRAWAL (<i>Alternate</i>)
Central Soil and Salinity Research Institute, Karnal	DR S. K. GUPTA
Central Water & Power Research Station, Pune	DR N. GHOSH SHRI R.S. RAMTEKA (<i>Alternate</i>)
Central Water Commission, Faridabad	SUPERINTENDING ENGINEER (PLANNING CIRCLE) DIRECTOR (WM) (<i>Alternate</i>)
Centre for Water Resources Development & Management, Kozhikode	HEAD DR E. J. JAMES (<i>Alternate</i>)
Geological Survey of India, Lucknow	SHRI S. KUMAR SHRI Y. DEVA (<i>Alternate</i>)
Ground Water Surveys and Development Agency, Pune	DR B. S. CHANDRASEKHAR SHRI S. P. BAGDE (<i>Alternate</i>)

IS 15797 : 2008

<i>Organization</i>	<i>Representative(s)</i>
Gujarat Water Resources Development Corporation, Gujarat	SHRI J. P. RAVAL SHRI A. D. GOHIL (<i>Alternate</i>)
India Meteorological Department, New Delhi	SHRI N. Y. APTE
Indian Institute of Technology, Roorkee	DR DEEPAK KHARE
Irrigation Department, Government of Punjab, Chandigarh	CHIEF ENGINEER DIRECTOR (<i>Alternate</i>)
Irrigation Department, Government of Uttarakhand, Dehra Dun	CHIEF ENGINEER SUPERINTENDING ENGINEER (I & PI) (<i>Alternate</i>)
Ministry of Environment & Forests, New Delhi	ADVISOR DR (SMT) NALINI BHAT (<i>Alternate</i>)
National Bureau of Soil Survey & Land Use Planning, New Delhi	DIRECTOR
National Geophysical Research Institute, Hyderabad	DR D. MURALIDHARAN
National Hydroelectric Power Corporation Ltd, Faridabad	SHRI IMRAN SAYEED SHRI P. PUNETHA (<i>Alternate</i>)
National Institute of Hydrology, Roorkee	DR A. K. BHAR DR N. C. GHOSH (<i>Alternate</i>)
National Remote Sensing Agency, Hyderabad	HEAD, HYDRO GEOLOGY DIVISION
North Eastern Region, Tejpur	DR P. V. SEETHAPATHI DR S. C. PATRA (<i>Alternate</i>)
River Research Institute, Government of West Bengal, Kolkata	SHRI R. CHAKRABORTY
Survey of India, New Delhi	BRIG G. S. CHANDELA SHRI C. B. SINGH (<i>Alternate</i>)
Water & Land Management Institute, Aurangabad	DR B. M. SAHNI SHRI B. B. JADIA (<i>Alternate</i>)
Water Technology Centre for Eastern Region, Orissa, Bhubaneswar	SHRI R. C. SRIVASTAVA
BIS Directorate General	SHRI A. M. DAVID, Director (WRD) [Representing Director General (<i>Ex-officio</i>)]

Member Secretary
Ms BHAVANA SHARMA
Assistant Director (WRD), BIS

Bureau of Indian Standards

BIS is a statutory institution established under the *Bureau of Indian Standards Act, 1986* to promote harmonious development of the activities of standardization, marking and quality certification of goods and attending to connected matters in the country.

Copyright

BIS has the copyright of all its publications. No part of these publications may be reproduced in any form without the prior permission in writing of BIS. This does not preclude the free use, in the course of implementing the standard, of necessary details, such as symbols and sizes, type or grade designations. Enquiries relating to copyright be addressed to the Director (Publications), BIS.

Review of Indian Standards

Amendments are issued to standards as the need arises on the basis of comments. Standards are also reviewed periodically; a standard along with amendments is reaffirmed when such review indicates that no changes are needed; if the review indicates that changes are needed, it is taken up for revision. Users of Indian Standards should ascertain that they are in possession of the latest amendments or edition by referring to the latest issue of 'BIS Catalogue' and 'Standards : Monthly Additions'.

This Indian Standard has been developed from Doc : No. WRD 3 (369).

Amendments Issued Since Publication

Amend No.	Date of Issue	Text Affected

BUREAU OF INDIAN STANDARDS

Headquarters :

Manak Bhavan, 9 Bahadur Shah Zafar Marg, New Delhi 110 002
Telephones : 2323 0131, 2323 3375, 2323 9402

Telegrams : Manaksanstha
(Common to all offices)

Regional Offices :

	Telephone
Central : Manak Bhavan, 9 Bahadur Shah Zafar Marg NEW DELHI 110 002	{ 2323 7617 2323 3841
Eastern : 1/14 C.I.T. Scheme VII M, V. I. P. Road, Kankurgachi KOLKATA 700 054	{ 2337 8499, 2337 8561 2337 8626, 2337 9120
Northern : SCO 335-336, Sector 34-A, CHANDIGARH 160 022	{ 260 3843 260 9285
Southern : C.I.T. Campus, IV Cross Road, CHENNAI 600 113	{ 2254 1216, 2254 1442 2254 2519, 2254 2315
Western : Manakalaya, E9 MIDC, Marol, Andheri (East) MUMBAI 400 093	{ 2832 9295, 2832 7858 2832 7891, 2832 7892
Branches : AHMEDABAD. BANGALORE. BHOPAL. BHUBANESHWAR. COIMBATORE. FARIDABAD. GHAZIABAD. GUWAHATI. HYDERABAD. JAIPUR. KANPUR. LUCKNOW. NAGPUR. PARWANOO. PATNA. PUNE. RAJKOT. THIRUVANANTHAPURAM. VISAKHAPATNAM.	